

The **Southern Nevada Health District**
Environmental Health Division
invites you to attend the

Food Safety Partnership

**Tuesday, June 23, 2026
1:30 PM – 3:30 PM**

All are welcome to attend this virtual meeting.

The meeting will begin soon



Food Safety Partnership Meeting



- Thank you for attending!
- Platform: Teams Webinar
- You are not able to unmute or show your camera.
- Use Q&A to send questions and comments.
- A copy of the slides will be posted on www.snhd.info/ehrcp

Agenda

- SNHD Environmental Health Introductions**
- ACA Walk-Through – Overall** by Michelle Guzman and Tara Edwards
- ACA Walk-Through – Plan Review** by Candice Humber
- Unpermitted Vending/Sidewalk Vending** by Tom Sheffer
- Q&A**

Food Operations Leadership Team

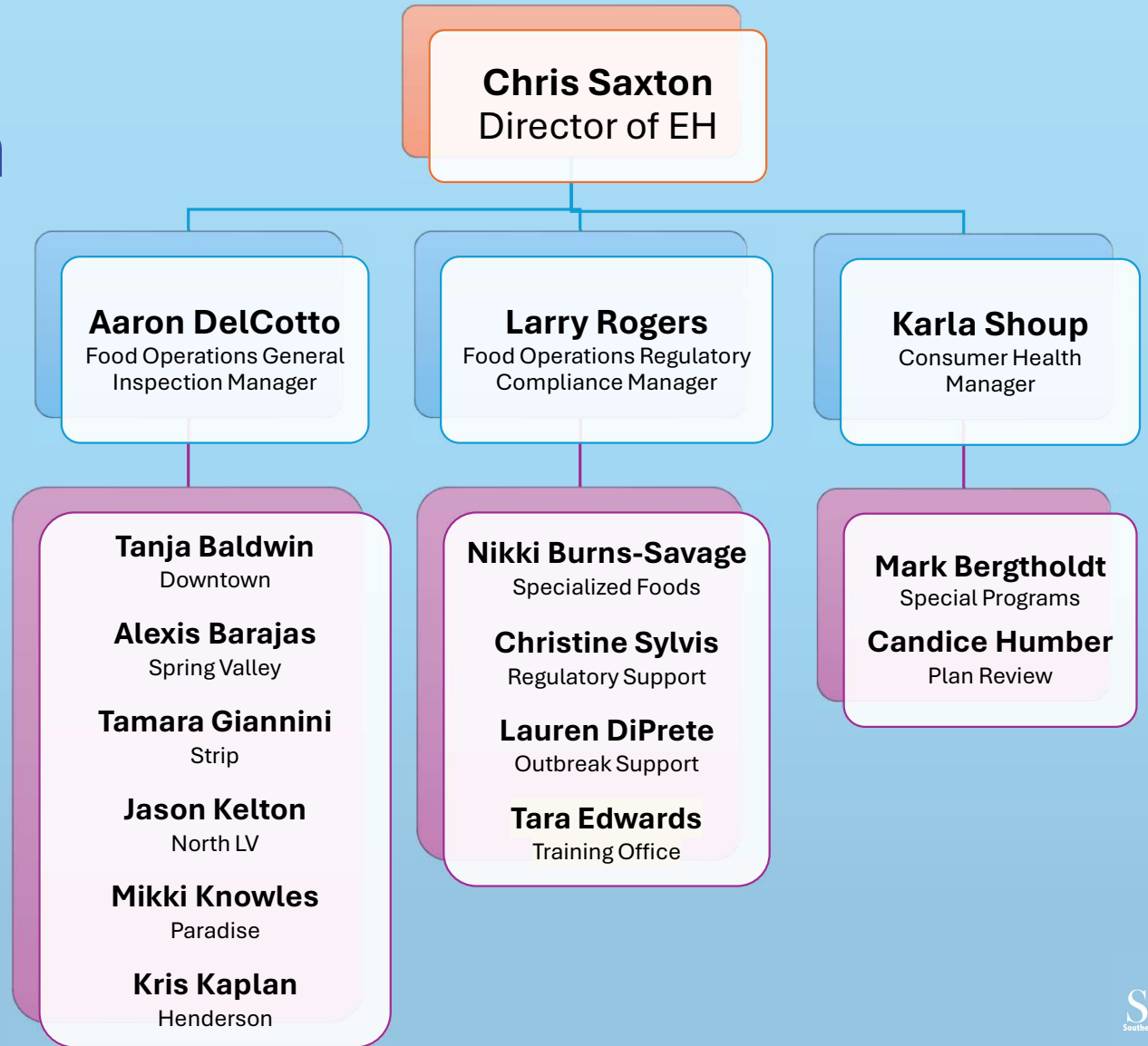

Environmental Health Portal Overview

- Food Safety Partnership Meeting 06/23/2026
- Southern Nevada Health District, EH Training Office

On **4/27/26** the Environmental Health Division launched a new online portal for managing all new and existing Environmental Health permits

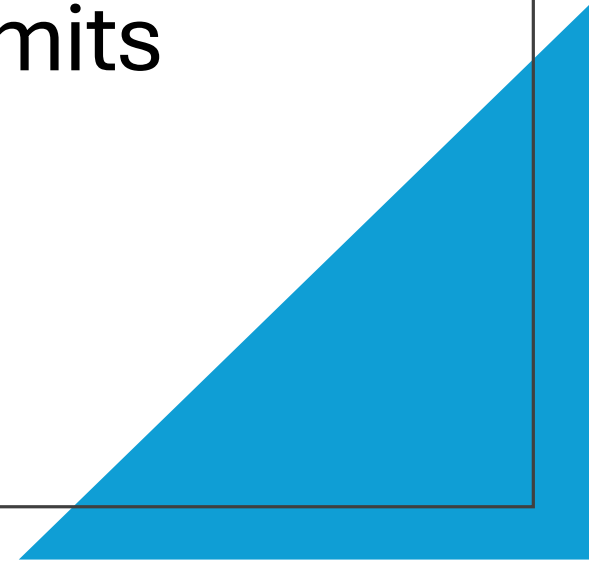

The online portal, Accela, provides existing permit holders and new applicants 24/7 access to online services including:



Apply for new permits and remodels



Check application status



Pay for any Environmental Health fees



Update your contact information



Review inspection reports

Getting started

- Resources for using the online portal, including video tutorials and handouts in both English and Spanish, are available at www.snhd.info/ehportal

Environmental Health Portal

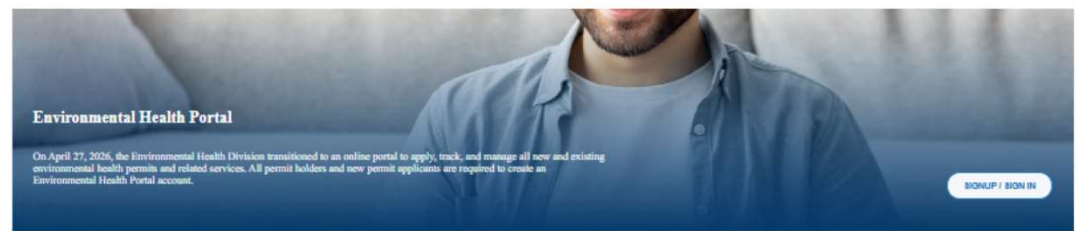

Resources & Tutorials

English

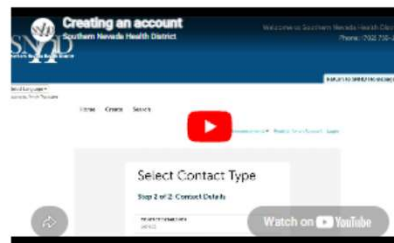

- How to Create an Account
- How to Link a Permit
- How to Link a Permit
- How to Apply for a Permit
- How to Apply for a Permit
- How to Pay Fees
- How to Add a Delegate

Español



- Cómo Crear una Cuenta
- Como Enlazar un Permiso
- Como Enlazar un Permiso
- Cómo Solicitar un Permiso
- Cómo Solicitar un Permiso
- Cómo Pagar Cargos
- Cómo Asignar un Delegado

Beginning Friday, May 1st, 2026, we will be hosting office hours for those needing assistance with their accounts. Please see our website for more information. The last individual will be admitted 15 minutes before the scheduled end time. Individuals applying for a permit must have all required information ready to submit.

Southern Nevada Health District Main Facility
3000 S. Las Vegas Blvd., Suite 1000, Las Vegas, NV 89102

Overview of how to use Accela:

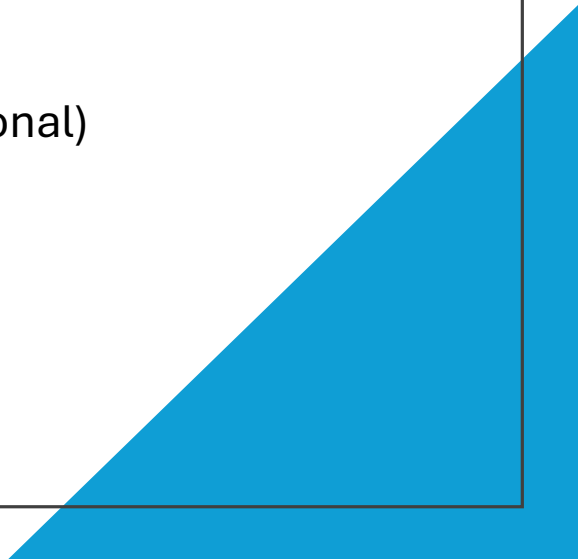
1. Create an account
 2. Link existing permits to your account
 3. Invite delegates to help you manage your account (optional)
 4. Pay fees, including annual permit fees
 5. Print health permits
 6. View inspection reports
- 

Creating an account

- To use all the services provided you must register and create a user account
 - An account is not needed to file an environmental health complaint
- Visit the Environmental Health Portal at <https://aca-prod.accela.com/SNHD/Default.aspx> and click “Create an Account”

The screenshot shows the Southern Nevada Health District (SNHD) Citizen Portal. At the top, there is a blue header with the SNHD logo and the text "Welcome to Southern Nevada Health District!!" and "Phone: (702) 759-1000". Below the header, there are navigation links for "Home", "Create", and "Search". On the right side, there are links for "Announcements", "Register for an Account", and "Login". The main content area is divided into two columns. The left column contains a "Welcome to the new Citizen Portal" message, a paragraph about the partnership with Accela, Inc., and a section titled "What would you like to do today?" with links for "Env Health", "File a Complaint", and "Search". The right column contains a "Sign In" form with fields for "USERNAME OR EMAIL" and "PASSWORD", a "Forgot Password?" link, a "SIGN IN" button, and a "Remember me on this device" checkbox. At the bottom of the sign-in form, there is a link for "Not Registered?" and a "CREATE AN ACCOUNT" button, which is circled in red.

Creating an account

- Follow the prompts, complete the required fields (marked with a red asterisk*)
- You will be asked to create a username and a unique password
 - Passwords must be 8-20 characters and contain at least 1 special character, 1 number, and 1 capital letter
- You will also be asked to create a security question
 - IMPORTANT: Security question answers are case sensitive

Login Information

Step 1 of 2: Account Details

* Required Fields

USERNAME:*

E-MAIL ADDRESS:*

PASSWORD:*

TYPE PASSWORD AGAIN: *

ENTER SECURITY QUESTION:*

ANSWER:*

I agree to the above terms [Terms of Service](#)

CONTINUE

Home Create Search

Announcements Register for an Account **Login**



Your account is successfully registered.

Congratulations. You have successfully registered an account. Login Now to create new applications.

Account Information

User Name: Training Office
E-mail: EHTRAININGOFFICE@SNHD.ORG
Password: *****
Security Question:
In what city or town does your nearest sibling live?

Contact Information

Training Office Home Phone: 7027590583
Training Officer Work Phone:
SNHD Training Mobile Phone:
EHTRAININGOFFICE@SNHD.ORG

Contact Address List

▼ Contact Addresses

Showing 1-1 of 1

Logging into your account

- Once you have successfully registered for an account, return to the main screen to login using the username/email and password you just created

Linking permits to your account

If you have existing SNHD permits will need to link those permits to your account

You will be asked to provide a **permit number** and **pin** for each existing permit you would like to add to your account



Permit linking

- **To obtain the permit number and pin:**
- If you were previously enrolled in electronic invoicing, an automated email with this information was sent from Auto_Sender@accela.com on 4/27/26
- If you were not previously enrolled in electronic invoicing, this information will be mailed with the annual permit fee invoice on ~7/1/26
- You may also contact environmentalhealth@snhd.org to request this information
 - Include the facility ID or permit number(s) with the request
 - Requests will be processed in the order they're received

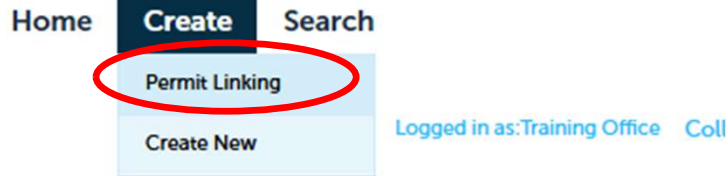

Welcome Training Office

You are now logged in.

What would you like to do today?

To get started, select one of the services listed below:



Permit Linking

Permit ID:

PIN:

Submit Cancel

Permit linking

- Hover over “Create” and select “Permit Linking”
- Enter the permit ID and corresponding PIN (5 digits) for each permit you are linking
- Permit IDs consist of nine-digit alphanumeric characters and may begin with FA or PR



Facility permit IDs will link ALL environmental health permits under the same ownership at that location

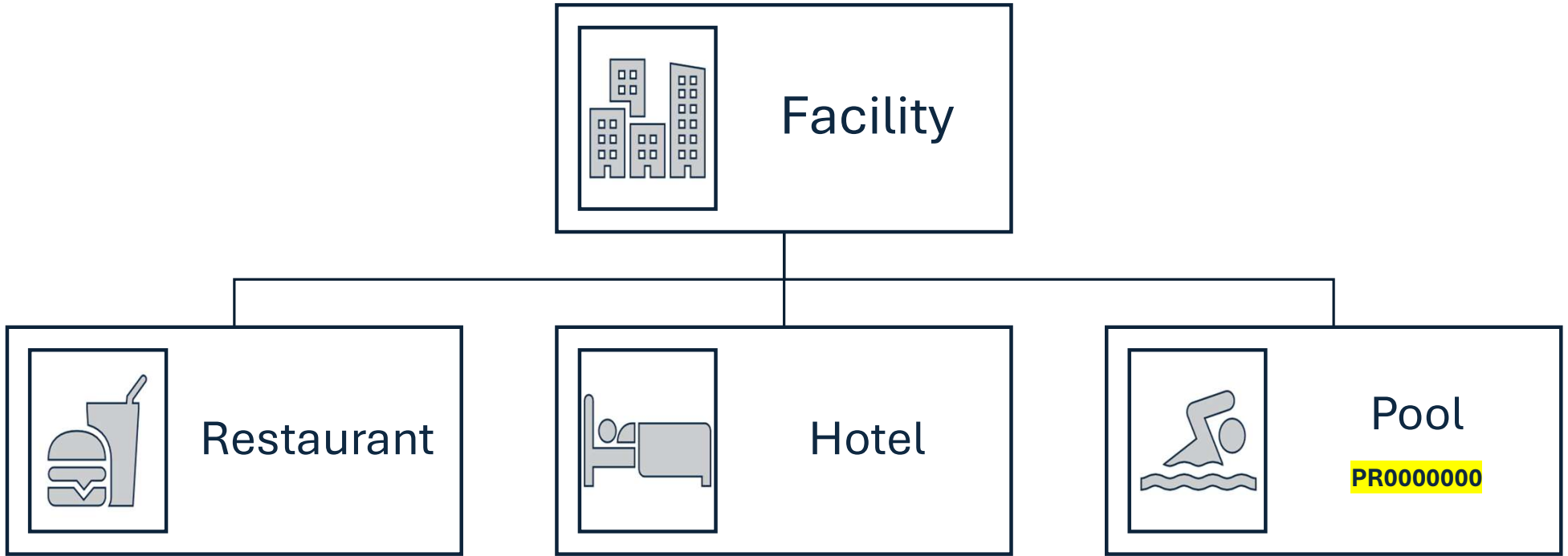

PR permit IDs will only link that specific permit

Linking permits

- It is recommended that you use the Facility ID to link permits to your account
- There is no limit to the number of permits that can be linked to one account,
 - Ten rows can be added at each time
 - However, the linking process may take longer for very large facilities with multiple permits

Adding a Delegate

- A delegate is an individual who you invite to help manage your records through the online portal
- Delegates must have already registered as users on the online portal
- To add a delegate, hover over “Home”, select “My Account”
- Scroll down & click on ‘Add a Delegate’



Adding a Delegate

- Enter in the name and email address of the user you'd like to invite to be a delegate of your account
- There are several permissions available to choose from based on the role of your delegate.
- Complete the required fields, select the appropriate delegate permissions, and click "Invite a Delegate" to complete this process.

Add a Delegate ×

Enter the name and e-mail address of the person to whom you would like to grant delegate access to your account.

* Name * E-mail Address

Set Delegate Permission

Delegates can view records across all categories unless you choose to restrict them to specific categories.

View Records in all categories [\(Change\)](#)

For the following permissions, the available categories are limited to the ones that you have granted the delegate access to view records.

- Create Applications in all categories [\(Change\)](#)
- Renew Records in all categories [\(Change\)](#)
- Amend Records in all categories [\(Change\)](#)
- Manage Inspections in all categories [\(Change\)](#)
- Manage Documents in all categories [\(Change\)](#)
- Make Payments in all categories [\(Change\)](#)

Add Personal Note

I'm not a robot  [Privacy - Terms](#)

[Invite a Delegate](#) [Cancel](#)

Adding a Delegate

- The delegate will receive an email notifying them of the invitation
- They will need to log into their own account, hover over “Home”, select “My Account”
 - Scroll down to the “Delegates” section and accept or reject the invitation

Delegates

[Add a Delegate](#)

People who can access my account

EH Training (EHTRAININGOFFICE@SNHD.ORG)

Invitation sent on 04/16/2026

[View Invitation](#)

[Add a Delegate](#)

People whose account I can access

None

Paying fees

- All fees assessed by the health district, including reinspection or closure fees and annual permit fees, can be paid through the online portal
- The permit(s) must already be linked to your account
- Hover over “Home”, select “My Records”

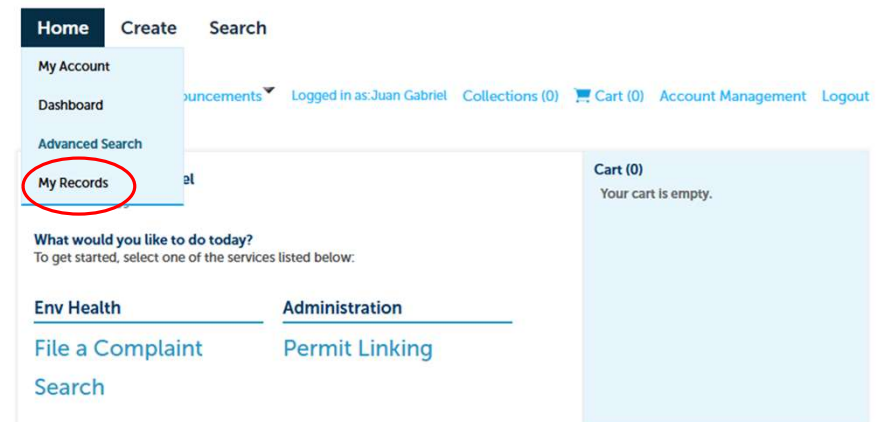

Paying fees

- If fees are due for a permit, the option to 'Pay Fees Due' will display next to the record
- If fees are not currently due, this option will not be present
- Select 'Pay Fees Due' to navigate to the payment processing site
 - If you would like to pay multiple fees at once, check the box next to each record with fees due and select 'Add to cart'

▼ Env Health

Showing 1-3 of 3 | [Download results](#) | [Add to collection](#) | [Add to cart](#)

<input type="checkbox"/>	Date	Record Number	Record Type	Description	Facility Name	Status	Action
<input type="checkbox"/>	04/14/2026	FOOD-A-25-0000196	Food Service		t	Pending	
<input checked="" type="checkbox"/>	04/03/2026	FOOD-A-25-0000084	Food Service		Buenos Tacos	Pending	Pay Fees Due
<input type="checkbox"/>	01/30/2025	PR0153098	Food Service Permit	TRAINING RESTAURANT	TRAINING EHS	ACTIVE, EXEMPT FROM BILLING	Pay Fees Due Amendment

Paying fees

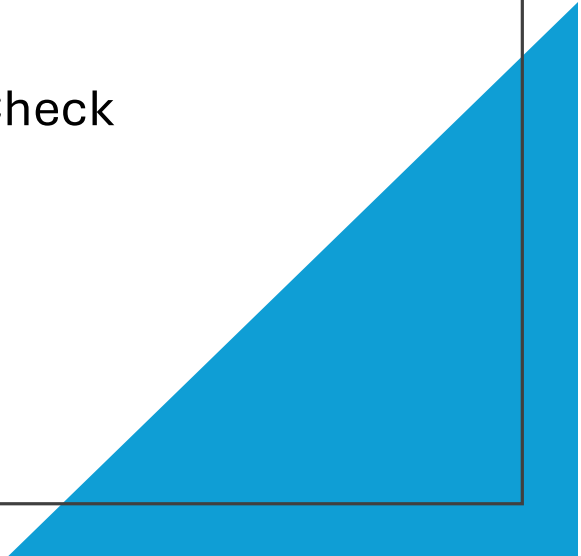
- Payment is made through a secure third-party payment processing site
 - Payment can be made in the form of credit card or eCheck
 - Payment information is not stored in your account
- 

ANNUAL PERMITS AND BILLING

- Annual health permits automatically renew on 7/1/26
- Fees for annual health permits will be assessed on or about 7/1/26
- If you have already signed up for an Accela account and linked your existing health permits, an email will be delivered to the accounts receivable contact alerting them when the annual permit fee is available to be paid online
- For all others, invoices will be delivered by mail to the accounts receivable address on file
 - Instructions for how to create an account and information for permit linking will be included with the invoice
 - Payment via the online portal is highly encouraged



Printing your health permit

- Once you have paid your annual permit fees, you will be able to print out the health permit from your account
- Hover over “Home”, select “My Records”

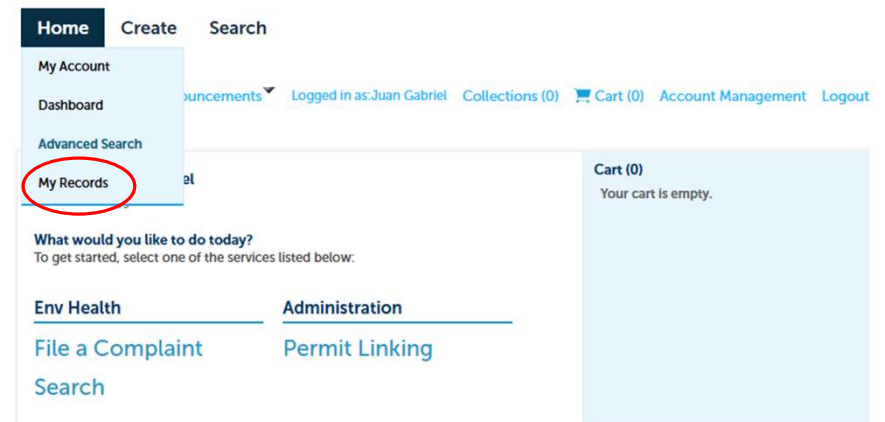

Printing your health permit

- Click on the “Record Number”

Showing 11-12 of 12 | [Download results](#) | [Add to collection](#) | [Add to cart](#)

<input type="checkbox"/>	Date	Record Number	Record Type	Description	Facility Name	Status	Action
<input type="checkbox"/>	01/30/2025	PR0153098	Food Service Permit	TRAINING RESTAURANT	TRAINING EHS	ACTIVE, EXEMPT FROM BILLING	Pay Fees Due Amendment

- Select “Attachments”

Record PR0153098: [Add to cart](#)
Food Service Permit [Add to collection](#)
Record Status: ACTIVE, EXEMPT FROM BILLING
Expiration Date: 07/01/2025

Record Info ▾ Payments ▾

Record Details

Processing Status

Attachments

Inspections

Las Vegas, NV 89107 *

Printing your health permit

- Locate the file type “Health Permit” and click on the file name
- A PDF copy of the health permit will then download
- Print and post in conspicuous location in your permitted facility

are disallowed file types to upload.

Type	Record ID	Record Type	Name	Entity Type	Size
<u>Health Permit</u>	PR0153098	Food Service Permit	<u>5001_AA_20260522_114134.pdf</u>	Record	189.3
Health Permit	PR0153098	Food Service Permit	5001_AA_20260522_114138.pdf	Record	189.3



POST IN A CONSPICUOUS PLACE

SNHD SOUTHERN NEVADA HEALTH DISTRICT
Southern Nevada Health District LAS VEGAS, NEVADA

HEALTH PERMIT

THIS CERTIFIES THAT THE ESTABLISHMENT LOCATED AT THE ADDRESS SHOWN BELOW AND OWNED AND/OR OPERATED BY ENTITY INDICATED HAS BEEN FOUND TO BE OPERATING IN CONFORMITY WITH THE HEALTH LAWS AND REGULATIONS PROMULGATED BY THE NEVADA DIVISION OF ENVIRONMENTAL PROTECTION AND THE SOUTHERN NEVADA DISTRICT BOARD OF HEALTH. THIS CERTIFICATE GRANTS THE APPLICANT APPROVAL TO OPERATE THE TYPE OF ESTABLISHMENT INDICATED, BUT IS REVOCABLE AT ANY TIME BY THE SOUTHERN NEVADA HEALTH DISTRICT OFFICER FOR FAILURE ON PART OF THE PERMITTEE TO MEET STATE AND DISTRICT HEALTH LAWS AND REGULATIONS.

OWNED AND OPERATED BY **TRAINING EHS LLC**

BUSINESS | ADDRESS **TRAINING EHS
280 S DECATUR BLVD
Las Vegas, NV 89107**

TYPE OF ESTABLISHMENT **RESTAURANT / TAKE OUT** PERMIT IS NOT TRANSFERABLE

DATE GRANTED | EXPIRES **06/30/2024 | 07/01/2025** PERMIT NUMBER **PR0153098**

CASSIUS LOCKETT, PHD | Chief Health Officer FEE PAID

ENVIRONMENTAL HEALTH SPECIALIST **Kristopher Kaplan** AREA **CLARK COUNTY**

All changes to your business must be submitted in writing to the Southern Nevada Health District.

Viewing inspection reports

- All inspection reports, including past inspections, may be viewed from your account and are available immediately after the inspection is completed
- Hover over “Home”, select “My Records”

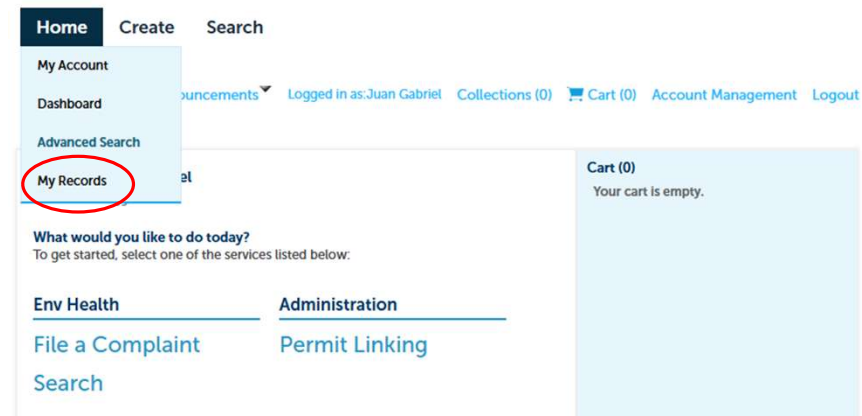

Viewing inspection reports

- Click on the “Record Number”

Showing 11-12 of 12 | [Download results](#) | [Add to collection](#) | [Add to cart](#)

<input type="checkbox"/>	Date	Record Number	Record Type	Description	Facility Name	Status	Action
<input type="checkbox"/>	01/30/2025	PR0153098	Food Service Permit	TRAINING RESTAURANT	TRAINING EHS	ACTIVE, EXEMPT FROM BILLING	Pay Fees Due Amendment

- Select “Attachments”

Record PR0153098: [Add to cart](#)
Food Service Permit [Add to collection](#)
Record Status: ACTIVE, EXEMPT FROM BILLING
Expiration Date: 07/01/2025

Record Info ▾ Payments ▾

Record Details

Processing Status

Attachments

Inspections

Las Vegas, NV 89107 *

Viewing inspection reports

- Locate the file type 'Historical inspections' and the appropriate 'Latest Update' date
 - NOTE: The 'Latest Update' date will NOT match the actual inspection date for past inspections but the file name may include the inspection date

Type	Record ID	Record Type	Name	Entity Type	Size	Latest Update
Historical Inspections	PR0153098	Food Service Permit	03-11-2021 EE7000956 5104 DAOHIV8B1 11.23.49 AM.PDF	Inspection	395.68 KB	05/10/2026
Historical Inspections	PR0153098	Food Service Permit	03-11-2021 EE7000956 5104 DAOHIV8B1 11.33.55 AM.PDF	Inspection	395.69 KB	05/11/2026

- Click on the file name
- A PDF copy of the inspection report will then download

Review of how to use Accela:

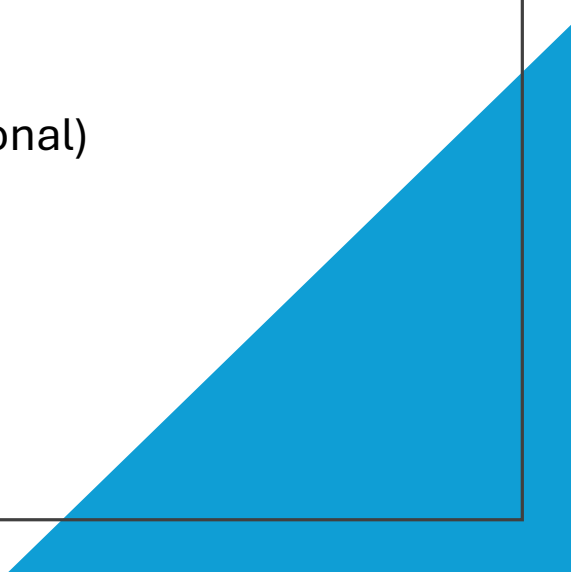
1. Create an account
 2. Link existing permits to your account
 3. Invite delegates to help you manage your account (optional)
 4. Pay fees, including annual permit fees
 5. Print health permits
 6. View inspection reports
- 

If you need assistance with any of these steps, you may contact us at environmentalhealth@snhd.org or (702) 759-0588

Office hours are being offered for in-person assistance

Mondays | 10:00 AM – 12:00 PM

Wednesdays | 8:00 AM – 11:00 AM

Southern Nevada Health District Main Facility

280 S. Decatur Blvd., Las Vegas, NV 89107

Plan Review Application Process

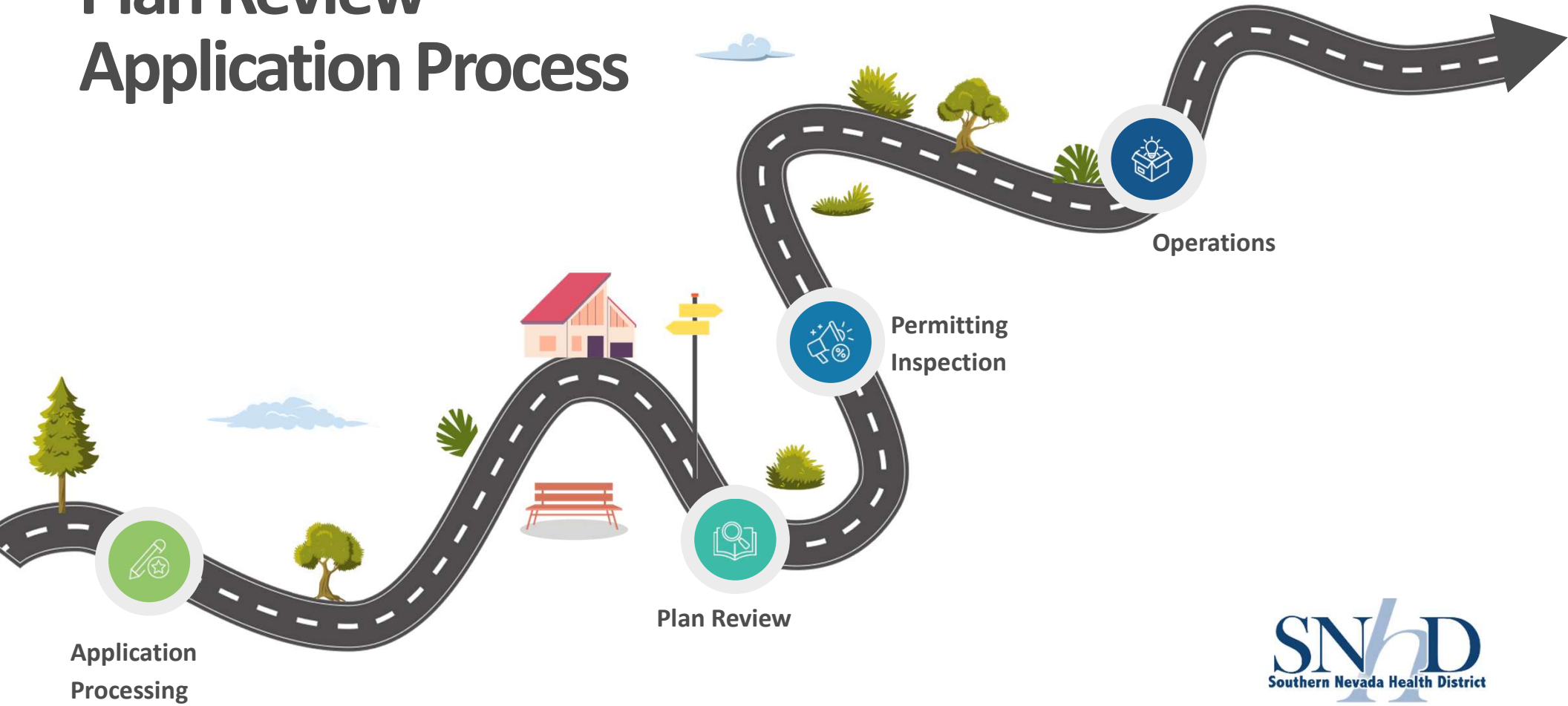

Timeline



Remodel

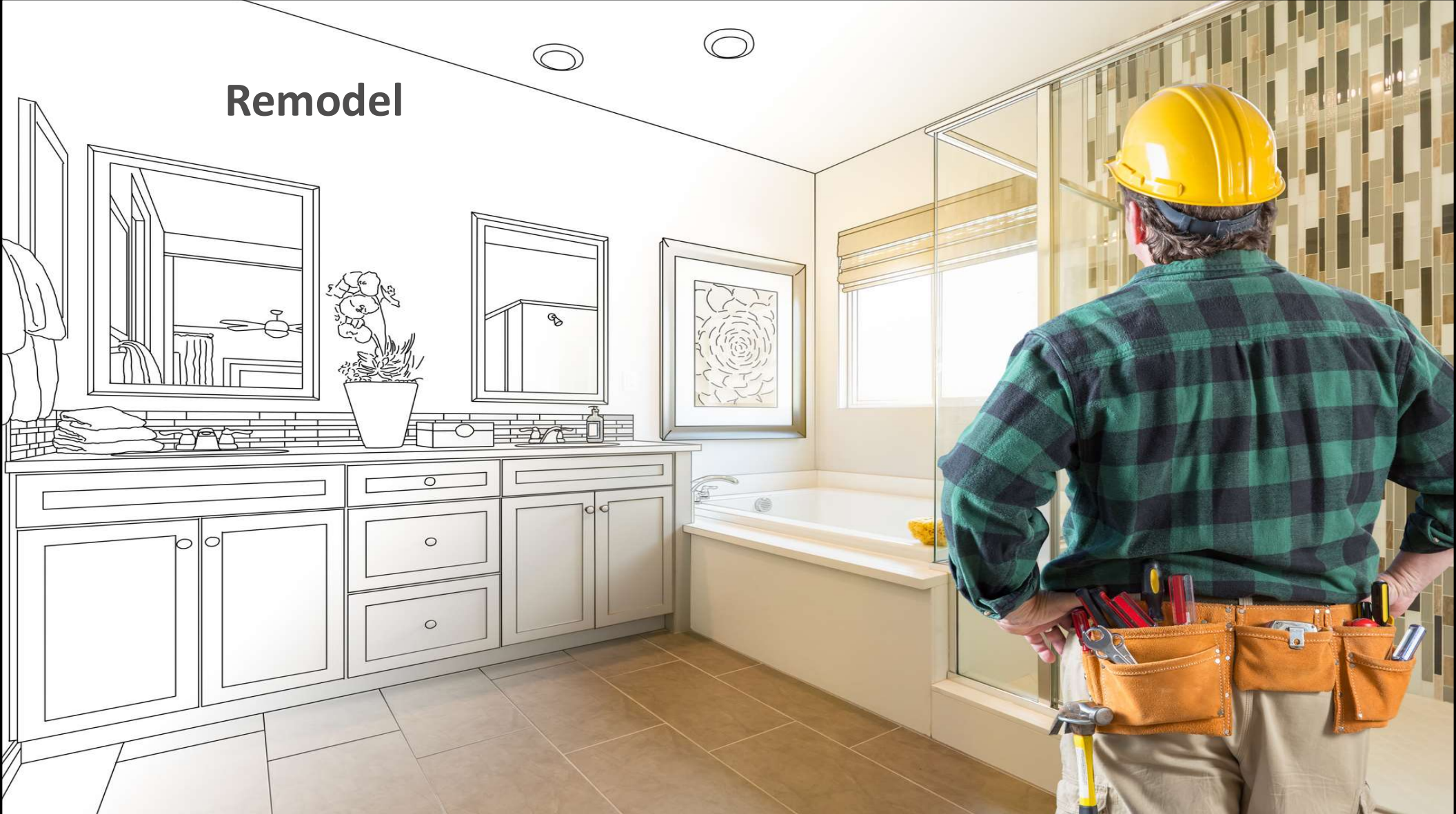

Select a Record Type

Choose one of the following available record types. You may type in a keyword such as sewer, food, or school to find the application you are looking for.

For assistance or to apply for a record type not listed below please contact us.

To apply for a remodel or a permit modification: Go to the Home screen, select My records, Locate the record and select "Amendment"



- ▶ Apply for a Permit
- ▶ Apply for a Temporary Permit
- ▶ Miscellaneous Items
- ▶ Register a Certified Professional
- ▶ Registration
- ▶ Request an Ownership Change
- ▶ Septic/Sewage Disposal System
- ▶ Subdivision/Parcel Map Plan Review
- ▶ File an Environmental Health Complaint
- ▶ File an Illegal Dumping Complaint
- ▶ File an Unpermitted Food Vendor Complaint
- ▶ Exemption



**Change of Ownership,
New Permit for Existing Facility,
Additional Health Permit, or
Health Permit for New Construction**

Select Language ▾

Powered by  Google Translate

Home Create Search

My Account

Dashboard

Advanced Search

My Records

Documents ▾

Logged in as: CANDICE HUMBER

Collections (0)

 Cart (1)

Account Management

Logout

CANDICE HUMBER



Saved in Cart (1)

View Cart

Food Service
FOOD-A-26-0000036
05/08/2026

\$815.00

Cart Total

\$815.00

My Collection (0)

View Collections

You do not have any collections
right now.

Work in progress 



View All Records

<input type="checkbox"/>	Date	Record Number	Record Type	Description	Facility Name	Status	Action
<input type="checkbox"/>	05/21/2026	CCC-R-26-0000001	Childcare Center Remodel	FOR TESTING - HUMBER ccc	FOR TESTING - HUMBER	In Progress	
<input type="checkbox"/>	05/01/2026	FAC-26-0000038	Environmental Health Facility	FOR TESTING PURPOSES	FOR TESTING PURPOSES	ACTIVE	
<input type="checkbox"/>	05/21/2026	FAC-26-0000211	Environmental Health Facility	FOR TESTING - HUMBER	FOR TESTING - HUMBER	ACTIVE	
<input type="checkbox"/>	05/01/2026	FOOD-A-26-0000036	Food Service	FOR TESTING PURPOSES	FOR TESTING PURPOSES	In Progress	Pay Fees Due
<input type="checkbox"/>	05/01/2026	FOOD-A-26-0000037	Food Service	FOR TESTING PURPOSES	FOR TESTING PURPOSES	In Progress	
<input type="checkbox"/>	05/21/2026	FOOD-A-26-0000193	Food Service	FOR TESTING - HUMBER	FOR TESTING - HUMBER	In Progress	
<input type="checkbox"/>	05/21/2026	FOOD-CO-26-0000009	Food Service Change Of Permit Holder	FOR TESTING - HUMBER	FOR TESTING - HUMBER	Closed	
<input type="checkbox"/>	06/17/2026	FOOD-P-26-0000204	Food Service Permit	FOR TESTING - HUMBER	FOR TESTING - HUMBER	ACTIVE, BILLABLE	Amendment
<input type="checkbox"/>	05/21/2026	FOOD-R-26-0000032	Food Service Remodel	FOR TESTING - HUMBER	FOR TESTING - HUMBER	In Progress	
<input type="checkbox"/>	05/21/2026	INS-A-26-0000003	Schools And Institutions	FOR TESTING - HUMBER	FOR TESTING - HUMBER	In Progress	

< Prev
1
2
3
Next >

[Plan Review](#)[Questionnaires for Plan Review](#)[Plan Review Resource Library](#)

Questionnaires for Plan Review

-  [Preliminary Questionnaire](#)
-  [Body Art Questionnaire](#)
-  [Childcare Questionnaire](#)
-  [Food Establishment Questionnaire](#)
-  [Remodel Questionnaire](#)
-  [School Questionnaire](#)

Submitting Additional Documents

- Home
- My Records
- Select Record
- Record Info
- Attachments
- Add



Record FOOD-P-26-0000204: Add to cart
Add to collection
Food Service Permit
Record Status: ACTIVE, BILLABLE
Expiration Date: 06/17/2026

Record Info Payments Conditions ²

 A notice was added to this record on 06/17/2026.
Condition: Remodel in Progress Severity: Notice
Total Conditions: 2 (Notice: 2)

After submitting the additional documents, please notify your inspector or foodrev@snhd.org

We are not automatically notified when documents are added.



Attachments

The file type must be one of the following: PDF, JPEG, PNG, GIF, DOC/DOCX, XLS, PPT/PPTX

The maximum file size allowed is 100 MB.

ade;adp;bat;chm;cmd;com;cpl;exe;hta;htm;html;ins;isp;jar;js;jse;lib;lnk;mde;mht;mhtml;msc;msp;mst;php;pif;scr;sct;shb;sys;vb;vbe;vbs;vxd;wsc;wsf; are disallowed file types to upload.

Type	Record ID	Record Type	Name	Entity Type	Size	Latest Update
No records found.						

Add

Processing Status

 Application Intake

Due on 05/23/2026, assigned to TBD
Marked as Accepted on 05/22/2026 by Candice Humber

*Due on 05/23/2026, assigned to TBD
Marked as Accepted on 05/26/2026 by Candice Humber*

 Body Art Plan Review

Due on 05/28/2026, assigned to TBD
Marked as Plan Approved on 05/26/2026 by Candice Humber

 Inspection

Due on 05/28/2026, assigned to TBD
Marked as Approved on 05/26/2026 by Candice Humber

Record Info ▼

Record Details

Processing Status 

Attachments

Inspections

Questions

Contact Us:

foodrev@snhd.org (Fastest Response Time)

(702) 759-1258 (Voicemail – With Details)

2830 E Fremont Street (Tuesday-Friday)

UNPERMITTED FOODS: A COLLABORATIVE RESPONSE

Specialized Food Office

Tom Sheffer, EHS II

WHAT IS AN UNPERMITTED FOOD VENDOR?

- Any facility which meets the definition of a Food Establishment and does not hold a valid health permit:
 - Any place, structure, premises, vehicle or vessel, or any part thereof, in which any food intended for ultimate human consumption is manufactured or prepared by any manner or means whatever, or in which any food is stored, sold, offered or displayed for sale, or served.



Food Establishment does not include:

(A) Private homes, unless the food prepared or manufactured in the home is sold, or offered or displayed for sale or for compensation or contractual consideration of any kind,

(B) Fraternal or social clubhouses that have a status as a 501 (c)(7) or (8), and which attendance is limited to members of the club,

(C) Vehicles operated by common carriers engaged in interstate commerce, or any third-party delivery service that delivers food from a food establishment does not directly handle unpackaged food.

(D) Any establishment in which religious, charitable and other 501(c)(3) nonprofit organizations sell food occasionally (no more than three occurrences in a 90-day period), on the premises of their organization, to raise money or in which charitable organizations receive salvaged food in bulk quantities for free distribution, unless the establishment is open on a regular basis to sell food to members of the general public,

(E) Any establishment where animals, including, without limitation, mammals, fish and poultry, are slaughtered which is regulated pursuant to NRS 583,

(F) Dairy farms and plants which process milk and products of milk or frozen desserts which are regulated under NRS 584,

(G) The premises of a wholesale dealer of alcoholic beverages licensed under NRS 369 who handles only alcoholic beverages which are in sealed containers,

(H) A facility that produces eggs which is regulated pursuant to NRS 583, (I) A cottage food operation that meets the requirements of NRS 446.866 with respect to food items as defined in that section,

(J) A craft food operation that meets the requirements of NRS 587.6945 with respect to food items as defined in that section,

(K) A farm for purposes of holding a farm-to-fork event,

(L) A kitchen in a private home,

(M) A bed-and- breakfast operation that is owner occupied, the number of available guest bedrooms does not exceed six, breakfast is the only meal offered, the number of guests served does not exceed 18, and the consumer is informed by statements contained in published advertisements, mailed brochures, and placards posted at the registration area that the food is prepared in a kitchen that is not regulated and inspected by the Health Authority,

(N) A permitted family or group care home.

(O) A permitted childcare center that serves only a limited menu as described in NRS 446.941,

(P) A demonstration kitchen or cooking class that does not store food or sell food to the public, or

(Q) An establishment that meets the exemption criteria pursuant to NRS 446.870 and NAC 446.042.



POST IN A CONSPICUOUS PLACE



SOUTHERN NEVADA HEALTH DISTRICT
LAS VEGAS, NEVADA

OWNED AND OPERATED BY

BUSINESS | ADDRESS

TYPE OF ESTABLISHMENT

DATE GRANTED | EXPIRES PERMIT NUMBER

ENVIRONMENTAL HEALTH SPECIALIST FEE PAID

AREA

All changes to your business must be submitted in writing to the Southern Nevada Health District.



WORKFLOW

- When complaints are received, they are reviewed to determine timeframe of response and if a multi-agency response is needed.
- The more details we have the better; times and days of operation; cross streets; description of vendor
- Home based complaints will be mailed a certified letter

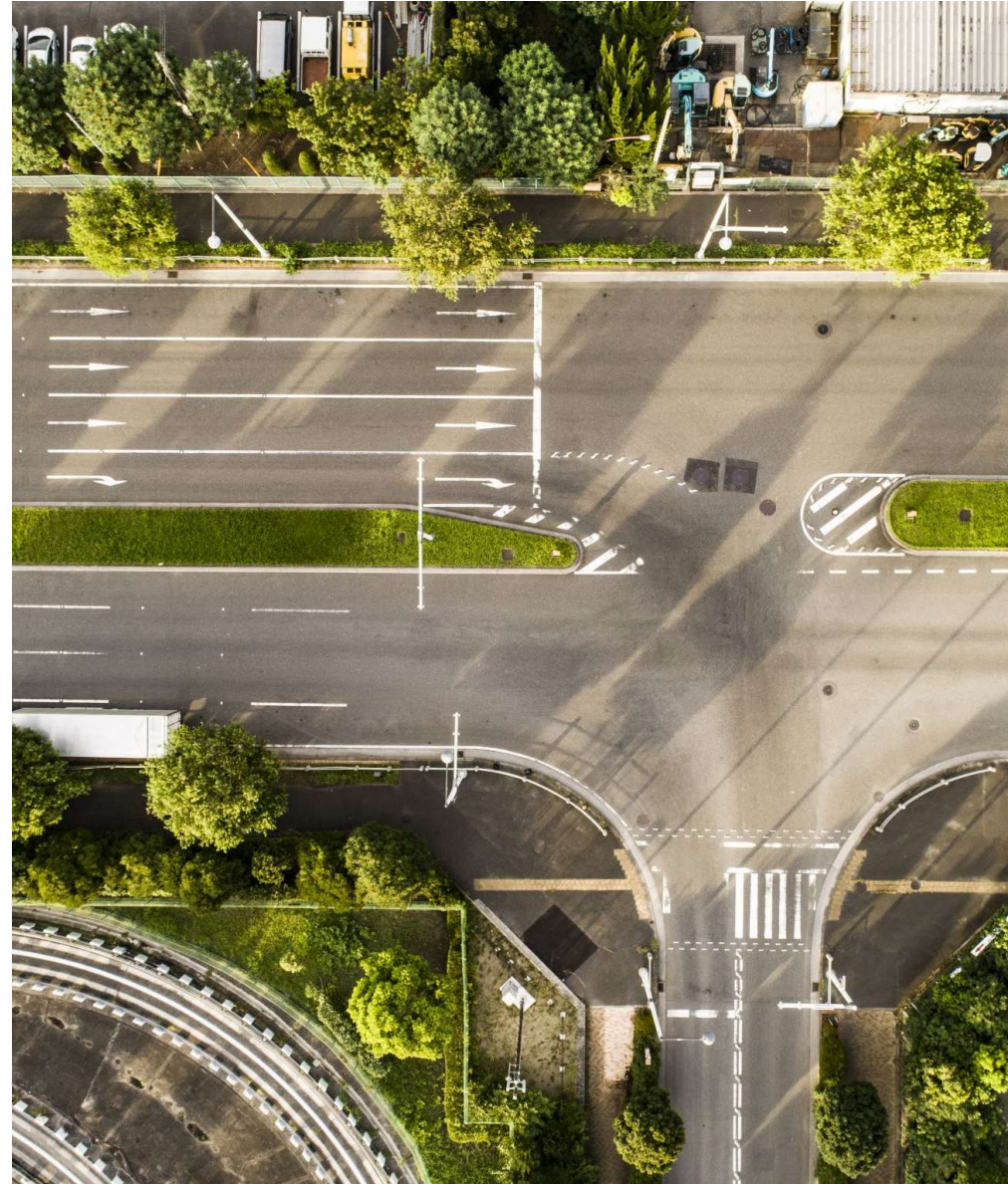



Date

CURRENT RESIDENT

Address

City, NV Zip Code

The Southern Nevada Health District (SNHD) recently received a complaint that there is an unpermitted food vendor operating at this address. Unpermitted vendors include any person selling food without a health permit or business license. Currently, there is no health permit on record for this location. Operating a Food Establishment without a permit from the Health Authority is a violation of Nevada Revised Statute (NRS) 446.870.

If unpermitted food activities are being conducted at this location, these operations are hereby ordered to immediately cease and desist. The sale and preparation of food is prohibited until a health permit is obtained through SNHD. Be advised that the persons engaged in such activity are guilty of a misdemeanor under NRS 446.945 and may be prosecuted by the District Attorney per NRS 446.943. Your information will be forwarded to the local licensing authority if unpermitted food activity is confirmed at this location.

To legally operate as a Food Establishment, you must first obtain a health permit. Contact SNHD's Plan Review Department at (702) 759-1258 to schedule an appointment. The Plan Review office is located at 2830 E. Fremont St. 89104.

Should you have any questions regarding this letter, contact SNHD's Unpermitted Food Vending Hotline at (702) 759-0523.

FIELD RESPONSE

- Investigations are conducted on survey form
- If vendors are located their food is condemned and confiscated for destruction



- **NRS 585.360 Food containing filthy, decomposed or putrid substance declared nuisance; condemnation or destruction by Commissioner.** Whenever the Commissioner or any of the Commissioner's authorized agents shall find in any room, building or other structure, or vehicle of transportation, any meat, seafood, poultry, vegetable, fruit or other perishable articles which are unsound, or contain any filthy, decomposed or putrid substance, or that may be poisonous or deleterious to health or otherwise unsafe, the same being hereby declared to be a nuisance, the Commissioner or the Commissioner's authorized agents shall forthwith condemn or destroy the same, or in any other manner render the same unsalable as human food.

Use % for partial match

Map navigation controls including zoom in (+), zoom out (-), home, and print icons.

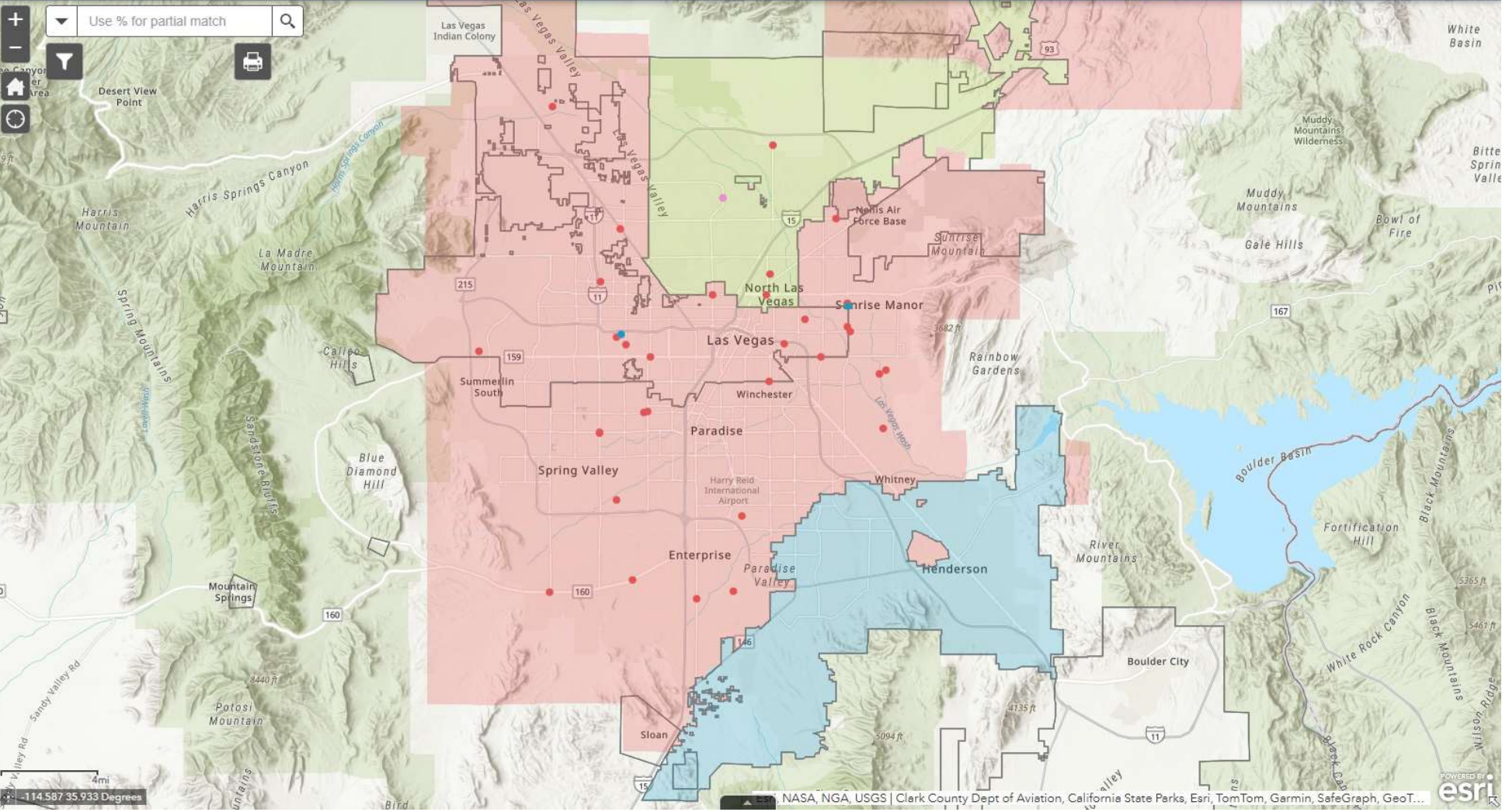

-114.587 35.933 Degrees



Fruta picada
El poblano



ELOTE

ELOTE MEXICANO

ESQUITE

TOSTI ELOTE

TOSTI LOCO

TAKY LOCO

TAKY ELOTE

CHEETO ELOTE

DORI ELOTE

DORI LOCO

MANGO

CHAMANGO

CHICHARRONES

Raspados

RASPADOS

CHURRO LOCO

MULTI-AGENCY RESPONSE



THE BIG 3

- **Business Licensing/Code Enforcement**-Issues Notices or Citations that escalate in severity; generally requires the worker/vendor to be identified. Sometimes approaches Vendors first, to confirm a transaction: City of Las Vegas, Clark County, Henderson, City of North Las Vegas
 - **Law Enforcement**-Mainly to "Keep the Peace" They function normally to enforce the law and protect everyone involved. They ensure the vendors/workers are compliant, and control the crowd: LVMPD (varies Area Commands), Henderson PD, City Marshals, NLVPD. Citation authority for operating without a license, DMV issues with vehicles, identification concerns.
 - **SNHD**-Performs an Investigation and determines the status of a Valid Health Permit-write a report, issue the NRS Notice, provide education/information, and confiscate food to be destroyed: Overseen by Specialized Food Office
-



UNPERMITTED COMMISSARY KITCHEN-609 E CAREY AVE

- SNHD notified by NLV Code Enforcement of house fire caused by unpermitted food activities
 - Multiagency response with NLV Code, Fire Dept, NLV BL, and NV Energy
 - The fire disrupted power for the entire block
 - SNHD conducted investigation of commissary activities; including storage, preparation, cooking, and distribution
 - Functioned as a central commissary for UPV Vans-Taco street vendors
 - All remaining food confiscated to be destroyed
 - Great team coordination effort!
-











UNPERMITTED COMMISSARY: FREMONT ST

- SNHD notified by City of LV Code Enforcement, that discovered an unpermitted commissary located on Fremont St
- Multi-agency response included LVMPD, Code Enforcement, Business Licensing, Fire Dept and NV LP Board
- Due to excessive propane tank storage (massive fire hazard), NV LP Board certified technician called for proper removal and disposal of all tanks
- Commissary served as main production and distribution of multiple taco stands throughout the valley; food, storage, equipment, vehicles, and housing for workers
- Fire Dept declared the building (second floor) structurally unsound...







SYP

36.16335770, -115.12531512 3/7/2024 10:25:27



s/p

36.16331768, -115.12530060 3/7/2024 10:25:14



snp

36.16267578, -115.12513457 3/7/2024 10:12:38



snp

36.16269887, -115.12487348 3/7/2024 10:12:57



Joint enforcement with North Las Vegas

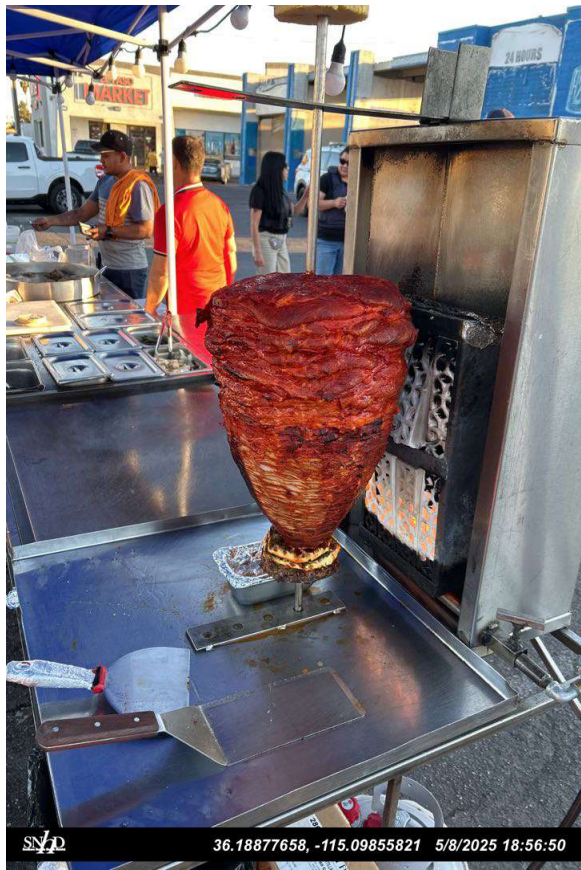
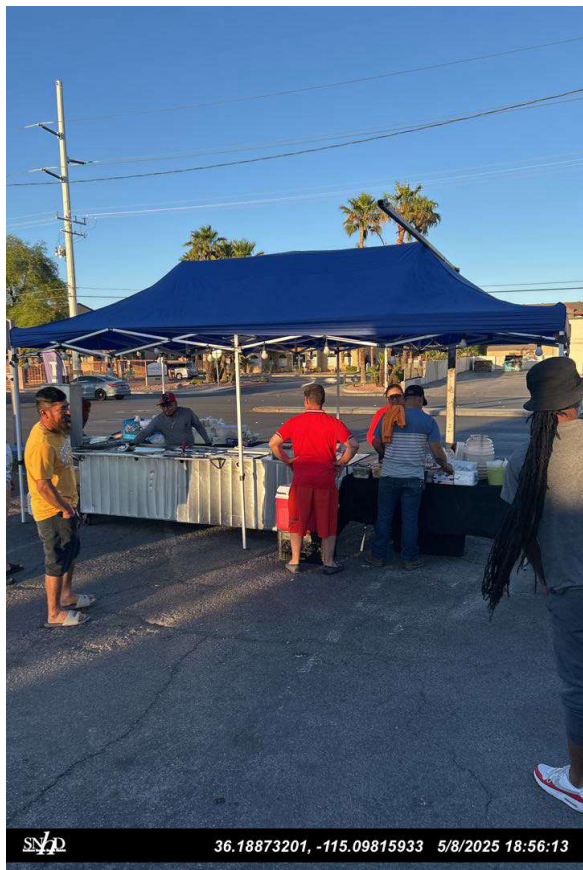



Joint enforcement Metro SIS (Special Investigations Section)



SND

36.17087390, -115.20956740 6/8/2021 12:22:58



SNIP

36.17087390, -115.20956740 6/8/2021 12:26:20





TRADITIONAL UNPERMITTED STREET VENDORS

- Street Vendors-Taco Stands
- Trike/Carts-corn, shaved ice, snacks, etc
- Golf Carts
- Fruit Carts-prepared, cut fruit
- Juice Stands-aguas frescas
- Ice Cream Stands
- Tamale Vans/Cars/Stands
- Empanada Stands
- Trunk Seafood
- Can be located everywhere; street corners, neighborhoods, schools, parks, parking lots, construction areas
- Five Major Risk Factors uncontrolled





NIEVES DE GARRAFA
Limon • Mango • Vainilla
Coco • Nuez y mas...



HOW MANY COMPLAINTS?!

- FY23-24 CLOSED 205 complaints
- FY24-25 (through May 28, 2025) CLOSED 735 complaints*

*several old complaints from previous year and duplicate complaints closed during this time



UPV-COMPLAINT INVESTIGATION FORM

SNHD Southern Nevada Health District		SOUTHERN NEVADA HEALTH DISTRICT Report and Notice of Inspection				Page 1 of 1													
280 SOUTH DECATUR BLVD • LAS VEGAS, NV • 89107 • 702-759-1110 (DIRECT) • 702-759-1000 (24 HOURS)																			
FACILITY INFORMATION																			
PERMIT #	ESTABLISHMENT NAME			PHONE #	COMPL. SCHED DUE		PRIMARY EHS												
ADDRESS				RISK CAT.	F.E. Code	DISTRICT	LOCATION												
							RECORD ID												
CONTACT PERSON:																			
QUALITY ACTION	EHS	SERVICE	DATE	TIME IN	TIME OUT	TRAVEL MIN	PERMIT STATUS												
RESULT				QUALITY ACTION	ACTION		DATE												
SPECIAL NOTES																			
- NOTIFIED OF THE FOLLOWING -																			
<p>NRS 585.360 Food containing filthy, decomposed or putrid substance declared nuisance; condemnation or destruction by Commissioner. Whenever the Commissioner or any of the Commissioner's authorized agents shall find in any room, building or other structure, or vehicle of transportation, any meat, seafood, poultry, vegetable, fruit or other perishable articles which are unsound, or contain any filthy, decomposed or putrid substance, or that may be poisonous or deleterious to health or otherwise unsafe, the same being hereby declared to be a nuisance, the Commissioner or the Commissioner's authorized agents shall forthwith condemn or destroy the same, or in any other manner render the same unsalable as human food.</p> <p>[Part 4:177:1939; 1931 NCL § 6206.03]</p>																			
<table border="0" style="width: 100%;"> <tr> <td>Approved Food Source:</td> <td style="text-align: center;">IN</td> <td style="text-align: center;">OUT</td> <td>Foods protected from contamination:</td> <td style="text-align: center;">IN</td> <td style="text-align: center;">OUT</td> </tr> <tr> <td>Foods held at proper temperature:</td> <td style="text-align: center;">IN</td> <td style="text-align: center;">OUT</td> <td>Proper handwashing/No BHC:</td> <td style="text-align: center;">IN</td> <td style="text-align: center;">OUT</td> </tr> </table>								Approved Food Source:	IN	OUT	Foods protected from contamination:	IN	OUT	Foods held at proper temperature:	IN	OUT	Proper handwashing/No BHC:	IN	OUT
Approved Food Source:	IN	OUT	Foods protected from contamination:	IN	OUT														
Foods held at proper temperature:	IN	OUT	Proper handwashing/No BHC:	IN	OUT														
Food items confiscated for destruction:																			

RISK FACTORS ASSOCIATED WITH UNPERMITTED VENDORS

- Food from unapproved sources
- Poor personal hygiene/lack of adequate hand washing
- Improper cooking temperature
- Improper holding temperatures
- Food contamination



UPV-NRS NOTICE



280 S. Decatur Blvd
Las Vegas, NV 89107

The Southern Nevada Health District (SNHD) has determined that you have no health permit or business license, as proof you are legally not entitled to sell food to the public; you are in violation of Nevada Revised Statute (NRS) 446.020 and 870. You are subject to prosecution under provisions NRS 446.943 and penalty under NRS 446.945. As an illegal vendor, you are ordered to cease and desist all operations. Failure to comply will result in prosecution. Your food and means of conveyance may be confiscated and destroyed at our option. You may witness destruction of the food if you wish.

El Distrito de la Salud del sur de Nevada ha determinado que no tiene un permiso de salud o licencia comercial como prueba que usted es legalmente autorizado a vender alimentos al público; está en la infracción de NRS 446.020 y 870. Es susceptible a la prosecución bajo provisiones de NRS 446.943 y la pena bajo NRS 446.945. Como un vendedor ilegal, se le ordena dejar y desistir todas las operaciones. El incumplimiento tendrá como resultado prosecución. Su alimento y los medios de transporte pueden ser confiscados y pueden ser destruidos en nuestra opción. Usted puede ser testigo de la destrucción de la comida, si lo desea.

HOW TO OBTAIN A HEALTH PERMIT

Contact the Southern Nevada Health District Food Plan Review program to schedule an appointment.

You may schedule a free 15-minute consultation to discuss your business plan and equipment needs.

OR

You may schedule a full plan review appointment. Make sure to follow all instructions provided by the administrative assistant to ensure you are ready for the meeting. This includes the business plan, equipment list, lease, and/or commissary agreements. A fee applies.

SNHD FDAP

Phone: (702) 759-1258

Website: www.snhd.info/plan-review

Email: foodrev@snhd.org

Address: 2830 E. Fremont St.
Las Vegas, NV 89104



TO REPORT AN UNPERMITTED FOOD VENDOR

Call (702) 759-0523 or email
environmentalhealth@snhd.org

Stop spending
on vending!



SNHD
Southern Nevada Health District

BE 
VIGILANT
ABOUT  
VENDING
What is the Risk?



SNHD
Southern Nevada Health District

www.SNHD.info/illegal-vendors

DID YOU KNOW?

Eating food from illegal vendors can make you and your family sick with symptoms like **vomiting, diarrhea, abdominal cramps, and fever. Some people may experience even more serious health problems.**



Illegal vendors include any person selling any type of food without a health permit and/or business license. This can occur from a residence, a vehicle, a shopping cart, a table in a park, or on a street corner. Illegal street vendors often stand on a neighborhood street corner with bags of fruits and vegetables. In Clark County, street vendors are only permitted at farmers' markets and swap meets.



While purchasing from illegal vendors is a health risk, there is also a real danger that you may be enabling human trafficking and slavery by supporting these unpermitted businesses.

WHAT IS THE LAW?

NRS 446.870 Prohibited acts:

"Operation of food establishment without valid permit issued by health authority; sale, offer or display for consideration of food prepared in private home without valid permit issued by health authority; exemptions."

Permitted food operations in Southern Nevada are held to the **Southern Nevada Health District Regulations Governing the Sanitation of Food Establishments** standards on how to safely handle food and are regulated by the Health District. Illegal vendors may be preparing foods in an unsanitary manner, obtaining foods from unsafe sources, or not practicing proper hygiene.



REMEMBER to look for the vendor's **health permit, grade card, and/or mobile food vendor decal.** If they do not have one of these, they may be an illegal vendor.



EXCEPTIONS

If the vendor meets the criteria listed below, the vendor may be exempt from obtaining a health permit:

The **Cottage Food Law** allows the production of non-potentially hazardous foods, within certain limitations, for sale to the public from the home or farmers' market, swap meet, church bazaar, garage sale, or craft fair. **Cottage Food Vendors must register with the Health District.** You can find more details online at www.snhd.info/permits-and-regulations/cottage-food-operations.



The **Craft Food Law** allows the production of canned or jarred acidified foods such as pickles, salsa, and relishes produced and sold from home businesses as allowed under Senate Bill 441. These are regulated solely by the Nevada Department of Agriculture.

Phone: (775) 353-3758

Website: <http://agri.nv.gov/craftfoods>

Email: fnd@agri.nv.gov







CHANGES IN LEGISLATION



How does a bill become a law?

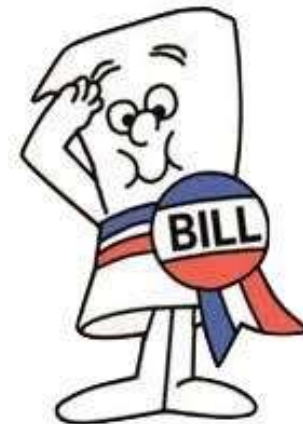
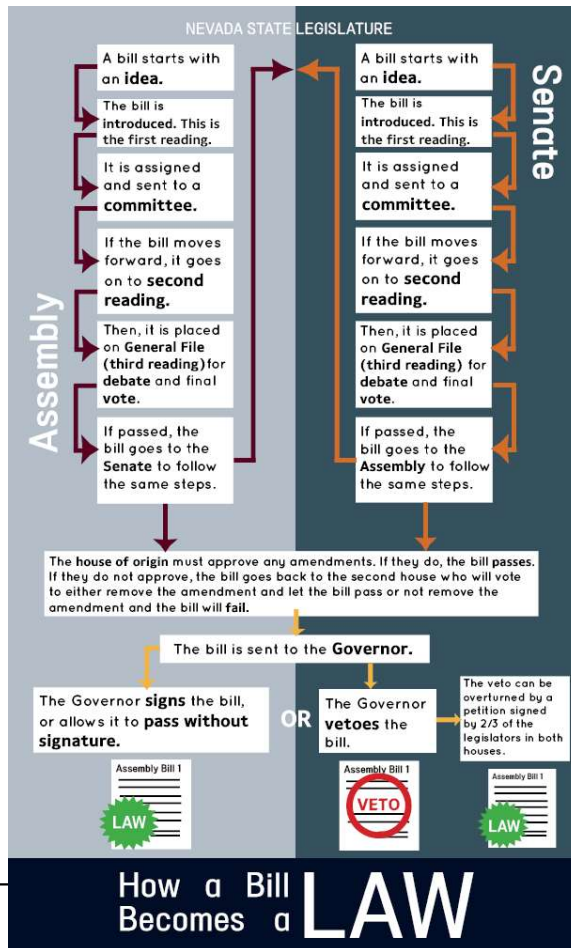

SB 92

SIDEWALK VENDING

- 82nd Session (2023)
- Established requirements for business licensing to license Sidewalk Vendors
- Required local boards of health to adopt regulations
- Setup a Task Force on Safe Sidewalk Vending



-
- Sidewalk vendor: a person who sells food upon a public sidewalk or other pedestrian path from a conveyance, including, without limitation, a pushcart, stand, display, pedal-driven cart, wagon, showcase or rack.
 - The term includes, without limitation, a nonstationary sidewalk vendor and a stationary sidewalk vendor.
-

OPERATIONAL RESTRICTIONS:

A person shall not sell food, beverages or merchandise upon a public sidewalk or pedestrian path from a conveyance, including, without limitation, a pushcart, stand, display, pedal-driven cart, wagon, showcase or rack, within 1,500 feet of:

- (a) A resort hotel, as defined in NRS 463.01865;
 - (b) An event facility that has seating capacity for at least 20,000 people and is constructed to accommodate a major or minor league sports team;
 - (c) A convention facility operated by a county fair and recreation board; or
 - (d) A median of a highway, if the median is adjacent to a parking lot.
-

MORE RESTRICTIONS

- (1) In areas located within the immediate vicinity of a farmers' market licensed pursuant to NRS 244.337 during the operating hours of the farmers' market.
- (2) Within the immediate vicinity of an area designated for a temporary special event by the board of county commissioners,
- (3) Within a set distance established by the board of county commissioners of: (I) Except as otherwise provided in section 7.5 of this act, an establishment that holds a nonrestricted gaming license described in subsection 1 or 2 of NRS 463.0177; (II) A food establishment; (III) A school, child care facility, community center, polling place, religious institution or place of worship or park or recreational facility owned by the county; or (IV) A highly trafficked pedestrian mall, convention center or designated entertainment district.
- (4) In residential areas, but must not prohibit nonstationary sidewalk vendors from operating in such areas.
-



Map of Prohibited Areas for Sidewalk Vending in Clark County

Created by GISMO

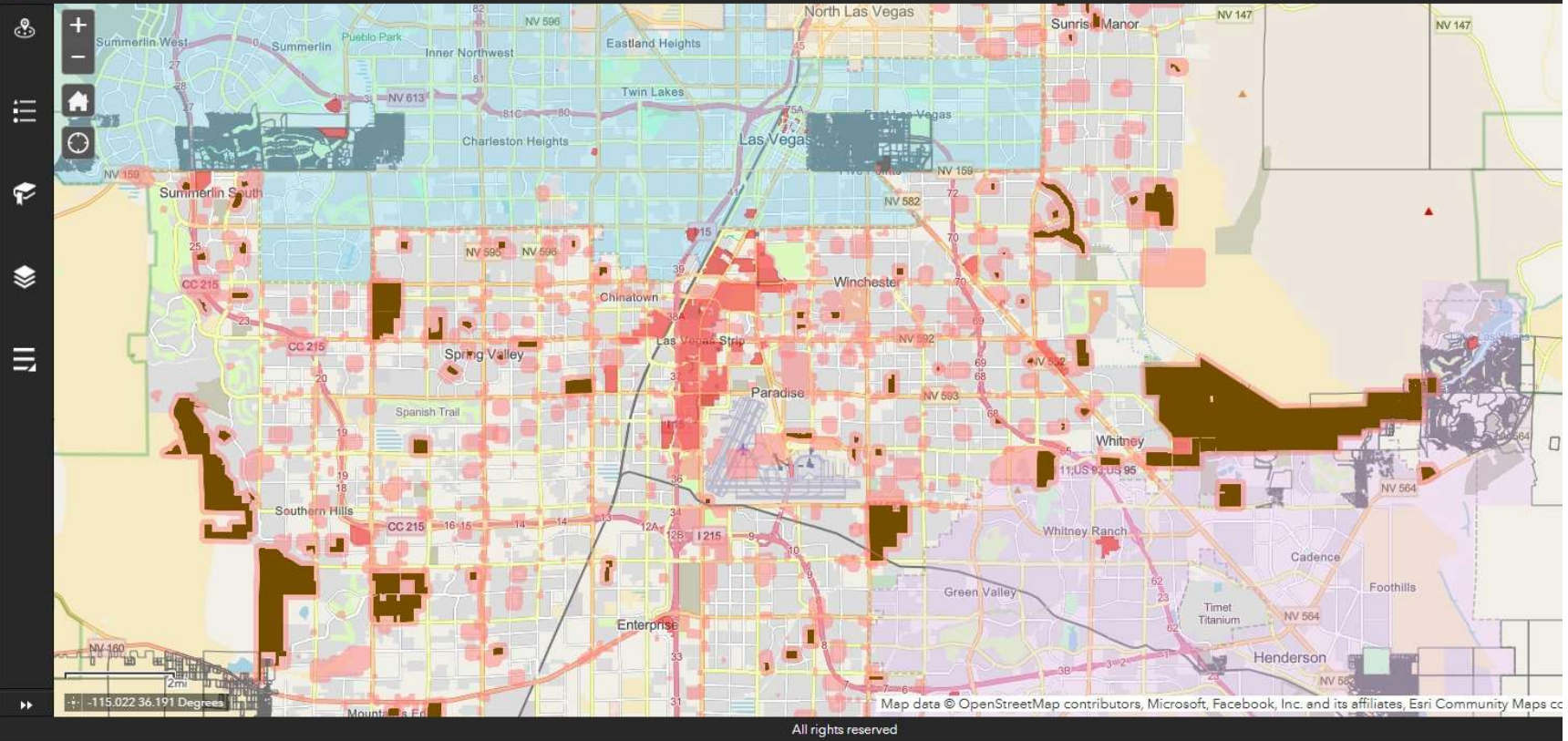

TASK FORCE ON SAFE SIDEWALK VENDING

The Task Force consists of the following nine members appointed by the Secretary of State:

- (a) A representative of a health district in a county whose population is 100,000 or more;
 - (b) A representative employed by a county or city whose primary duties are the performance of tasks related to business licensing;
 - (c) A representative of the gaming or restaurant industries in this State;
 - (d) A representative from a law enforcement agency in a county whose population is 100,000 or more;
 - (e) A representative from the Office of the Secretary of State; and
 - (f) Four members at large chosen by the Secretary of State, with priority given to persons who are sidewalk vendors or are affiliated with a community organization that represents and affiliates with sidewalk vendors.
-

The members of the Task Force:

- (a) Shall serve terms of 3 years. A member may be reappointed to the Task Force and any vacancy must be filled in the same manner as the original appointment.
- (b) Serve without compensation.

The Task Force on Safe Sidewalk Vending
created by section 13 of this act shall:

- (a) Review the existing laws of this State, the cities and counties in this State and those of other states and municipalities relating to sidewalk vending; and (b) Recommend approaches to improve the laws of this State and the cities and counties of this State to:
 - (1) Legalize sidewalk vending;
 - (2) Simplify and standardize the laws governing sidewalk vending;
 - (3) Remove unnecessary barriers to sidewalk vending;
 - (4) Protect the public health, safety and welfare by ensuring sidewalk vendors follow clear and narrowly tailored laws which address demonstrable health, safety and welfare risks; and
 - (5) Develop enforcement mechanisms, including, without limitation, civil penalties for sidewalk vendors that operate in authorized areas.
-

DISCUSSIONS WITH TASK FORCE

#1: Standardized Vending Regulations

After thorough review, further research into standardized vending regulations in which those governing food trucks and other similar food establishments. It is important that distance measures for food vendors are consistent with those applied to other food establishments. Should any reduction in distance easements be considered for food vendors, the same easement should be applied universally to all food establishments to prevent creating bias within the industry. This approach would ensure fairness and consistency across business and health licenses, thereby maintaining the integrity of the regulatory framework.

#2: Exemptions for Pre-Packaged Foods

NNPH and SNHD have confirmed that current regulations already accommodate exemptions for prepackaged foods, such as sealed bags of chips and whole, uncut fruits and vegetables. To ensure clarity, it is stipulated that vendors selling items like sealed bags of chips may offer a designated area on their carts where customers can add condiments, without triggering additional regulatory requirements. Furthermore, research conducted by Task Force members has identified that vendors selling sealed, uncut produce—such as whole oranges—are exempt from health regulations, provided that the natural protective barrier of the produce remains intact.

#3: Hand Washing Stations

NNPH and SNHD have clarified that when a street food vendor is associated with a partner commissary, such as a restaurant, and maintains proximity within 10 feet and clear access to the commissary's facilities, the hand washing station requirements for the vendor can be satisfied by the commissary's existing hand washing facilities



#4: Standard Plan for Food Carts

NNPH and SNHD have expressed a willingness to disseminate pre-approved cart designs tailored to specific food items for replication once one is submitted. It is important to emphasize that each food cart's approval is contingent upon the specific food items it intends to sell, with requirements varying accordingly. By providing public access to these pre-approved cart designs, NNPH and SNHD aims to alleviate many of the barriers that food vendors encounter in securing a cart that meets both their operational needs and regulatory standards. This initiative is intended to streamline the process for vendors, facilitating their compliance with health regulations while reducing the administrative burden associated with cart approval.

#5: Support Kitchen/Commissary Standards

NNPH and SNHD has provided clarification that current standards already permit restaurants to be approved as support kitchens or commissaries, provided that they meet the requisite support and commissary standards, including space requirements. Vendors bear the responsibility of identifying restaurants willing to partner with them to meet their operational needs. Additionally, the Vegas Chamber of Commerce has offered its assistance in bridging the gap between vendors and small businesses, thereby facilitating these partnerships. However, it is recommended that the Chamber's involvement be viewed as a resource rather than a mandated requirement for fostering these relationships.

#6: Community Kitchens

The Task Force acknowledges the potential for community kitchens, such as those located in community centers and churches, to meet the needs of street food vendors by expanding the availability of commissary spaces. Further investigation into potential grant or loan programs that could support the necessary modifications to these community locations, thereby enabling them to meet the standards required for use as commissaries. This approach could significantly enhance the capacity of community kitchens to serve as viable options for street food vendors, contributing to the overall sustainability of the vending industry.

#7: Auxiliary Handwashing Stations

NNPH and SNHD have demonstrated flexibility in the requirements for auxiliary handwashing stations. While it is not mandatory for a cart to be equipped with a built-in three-compartment sink one is required, however, a support kitchen or commissaries can serve as ware washing facilities where vendors can properly wash, rinse, and sanitize their equipment and utensils. The NNPH and SNHD has also clarified that even facilities such as gas stations may qualify as support kitchens if they possess the necessary equipment to fulfill the regulatory requirements

PATH TO SNHD PERMIT

- SNHD 2023 regulations (Chapter 11) allow for permitting as Open-Air Vendor
 - Will issue a waiver for regulation (11-201(A)) which requires operating from fixed location
 - Equipment requirements will be dependent upon menu and extent of food handling
-

OPEN AIR VENDOR EQUIPMENT REQUIREMENTS (11-102.1)

Be limited to 200 square feet

Provide an adequate number of handwashing sinks for open-food handling that meet the following criteria:

A handwashing sink must be stocked with liquid hand soap in a pump dispenser, single-use paper towels, and a garbage can

The handwashing sink must be located within 10 feet of the open-food handling area and ready for use prior to any open food handling,

(a) Provide a continuous flow of hot and cold running water without the use of a manual pump,

(b) Be self-contained, and

(c) Be equipped with an integral five-gallon minimum potable water supply tank and a wastewater storage tank that is at least 15% greater than the potable water supply

OPEN AIR VENDOR EQUIPMENT REQUIREMENTS

- Provide overhead protection for food preparation areas unless prohibited by fire code
 - Operate on a surface such as asphalt or concrete and provide adequate groundcover to prevent environmental contamination from excessive food debris and grease buildup on the ground
 - Food equipment must meet the standard for sanitation set by an American National Standards Institute accredited certification program
 - Common acceptable certifications: NSF, ETL Sanitation Listed; UL Sanitation
-

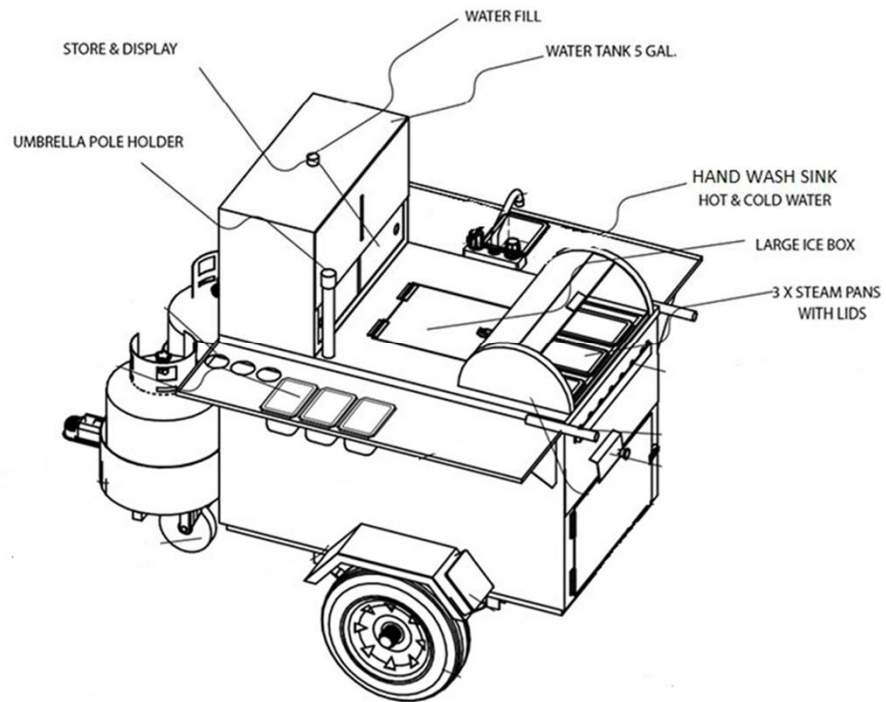

OPERATIONAL REQUIREMENTS FOR SIDEWALK VENDORS

- Sidewalk Vendors must follow all current regulations, which mandates they have a permit from the Health Authority.
 - May not conduct complex food processes such as cooling
 - May not hold open TCS food for next-day service
 - The operator is financially responsible for their permit(s), including any payment plans.
 - All other sanitary requirements for food establishments remain.
 - Food offered to the public may not be prepared from home kitchens.
 - Food must be:
 - Ingredients bought the same day and prepared at the sidewalk vendor location, or
 - Ingredients stored and food prepared at a permitted commissary location.
-





SN/D

36.17067721, -115.20810549 9/5/2024 8:26:17



PEPINO CON CUERITOS

HOT CHEETOS LOCOS

SQUIRT LOCO

MANGOS

CHICHARRONES
PORK RINDS

DORILOCOS

TOSTILOCOS

SANGRIA LOCA

Mexicanos



TAKILOCOS



FRUTA FRESCA
FRESH FRUIT



RASPADOS - SHAVED ICE
LIMON - FRESA - CHILI
TAMARINDO - VANILLA - MANGA
COCO - FRESA - GUAYABA - NARANJA



MANGONEADAS
& HOT CHEETOS



MANGONEADAS



ELOTE ENTERO
CORN ON THE CUP



TOSTILOCOS



SANGRIA LOCA



PEPINO CON CUERITOS



HOT CHEETOS LOCOS



SQUIRT LOCO



MANGOS



CHICHARRONES
PORK RINDS



TOSTIELOTES



DORILOCOS



ELOTE EN VASO
CORN ON THE CUP





Approximately 25 vendors currently permitted
as
sidewalk vendors







Submit complaints:

healthauthorityenforcement@snhd.org

English: 702-759-0523

Spanish: (702) 759-0674

EH Portal-Accela

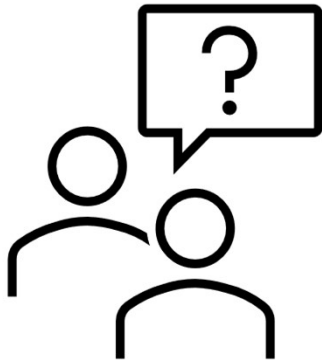

SpecializedFoods@snhd.org





Q&A Time

What's on your mind?
How can we help?

Please use the Q&A function to send questions or comments.

Thank you for joining us today!



**Next FSP Meeting is
November 3, 2026,
9:00AM**

Any suggested topics?



**Send comments,
questions, or
suggestions to:**
EHTrainingOffice@snhd.org



**Copy of presentation and
information for next
meeting at:**
www.snhd.info/ehrcp



**Contact us:
702-759-0500**