

General Guidance on Flushing Potable Premise Plumbing Systems



Public Water System and On-site Water Systems

An adequate supply of potable water is critical for any business. The public water system that provides water to a business makes sure that the water provided is safe and does not pose a risk to the public. A public water system's responsibility generally ends where the building's water meter or property's backflow preventer is located. Any part of the system on the building side of the meter or backflow preventer is the responsibility of the building owner. When a business closes for a period of time, the water in the plumbing of a building will become stale. That stale water may pose a hazard to the public if it is not flushed before use.

Generally, for small facilities, if the business was closed for more than one week, the potable water systems should be flushed for five minutes. Each hot and cold water fixture needs to be flushed to remove stale water. Toilet fixtures do not need to be included in this flushing program. A small facility would be a building less than three stories in height, less than 10,000 square feet, and with no more than six fixtures that provide potable water. Medium and large facilities have more complex water plumbing systems and should follow the more technical guidelines below as the complexity of the water systems for these buildings has more potential to be unsafe.

Premise Plumbing Following a Suspension of Use

Flushing the water in a medium and large facility needs to take into account water conservation, water cost, water volume, and time. Without access to equipment used to test the water, the duration of flushing will be key in determining when the stale water has been replaced with fresh water.

The diagrams below describe, in a schematic form, how flushing a water system can take place in a hypothetical building. Figure 1 represents the hypothetical premise plumbing system where the stale water is colored in orange. Generally, flushing should start at the fixture farthest from the building's water meter or backflow preventer. After flushing starts, the water temperature should be monitored. Once the temperature has stabilized, the fixture should be flushed for an additional fifteen minutes (Figure 2). This assumes that the freshest water from the water purveyor has replaced all water within the primary water line in the building (Figure 3). At the end of the fifteen minutes, note the temperature of the water. The final step of flushing a building's water system is to flush all of the branches from that primary water line. These branches typically lead to small fixtures, and flushing at these locations would last until water temperatures stabilize at the final temperature that was noted during the flush of the fixture farthest from the water meter or backflow preventer. Once that temperature has been reached, the fixture can be turned off (Figure 4). If there is no difference from the temperature of the water when the fixture is turned on and the temperature noted at the end of the above-noted fifteen-minute flush, then flush the fixture for at least five more minutes. This process needs to be repeated for the hot water side of the system, beginning with the fixture farthest from the water heater and can be done at the same time as the cold water side (depending upon water pressure). The above is meant as a generalized methodology for most premise plumbing systems. More complex systems may require a water management plan designed by a third party.

Additional information regarding prevention of disease through water management plans can be found at the CDC website [Prevention with Water Management Programs](#).

If you have any questions regarding flushing, please send an e-mail to environmentalhealth@snhd.org.

Continued on next page ►

◀ Continued from previous page

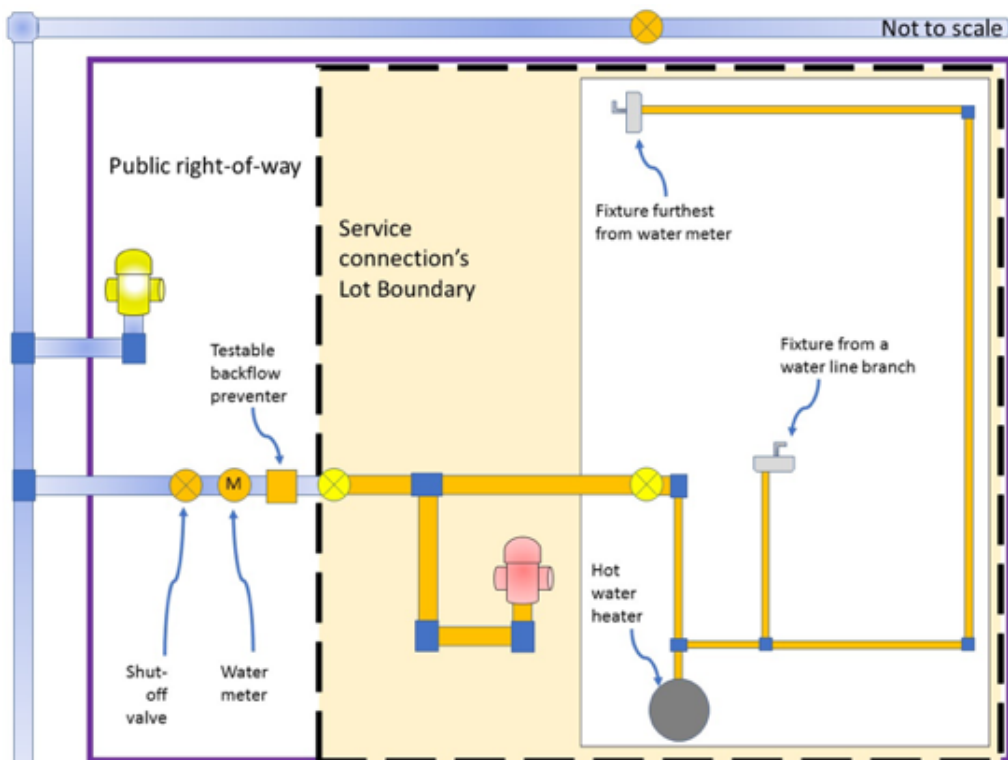

Figure 1. Hypothetical layout of a building's premise plumbing. Orange-colored lines represent aged water following a suspension of use.

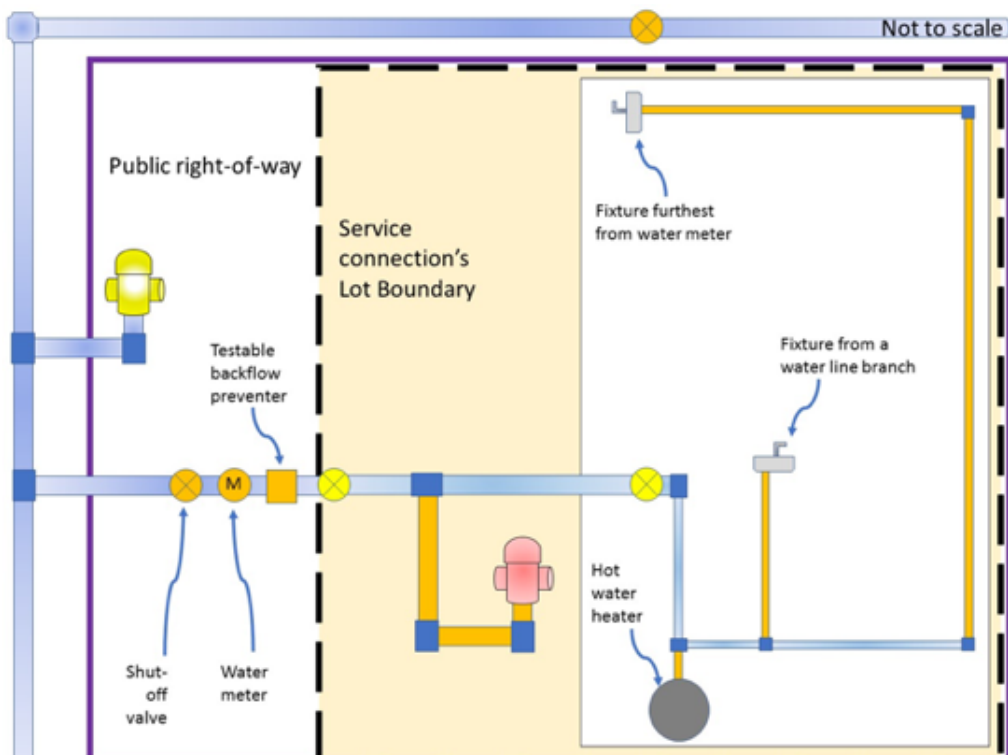

Figure 2. Hypothetical layout of a building's premise plumbing. Orange-colored lines represent aged water following a suspension of use. The fixture furthest from the water meter is being flushed. Note the blue fresh water replacing the orange stale water in the premise plumbing.

Continued on next page ▶

◀ Continued from previous page

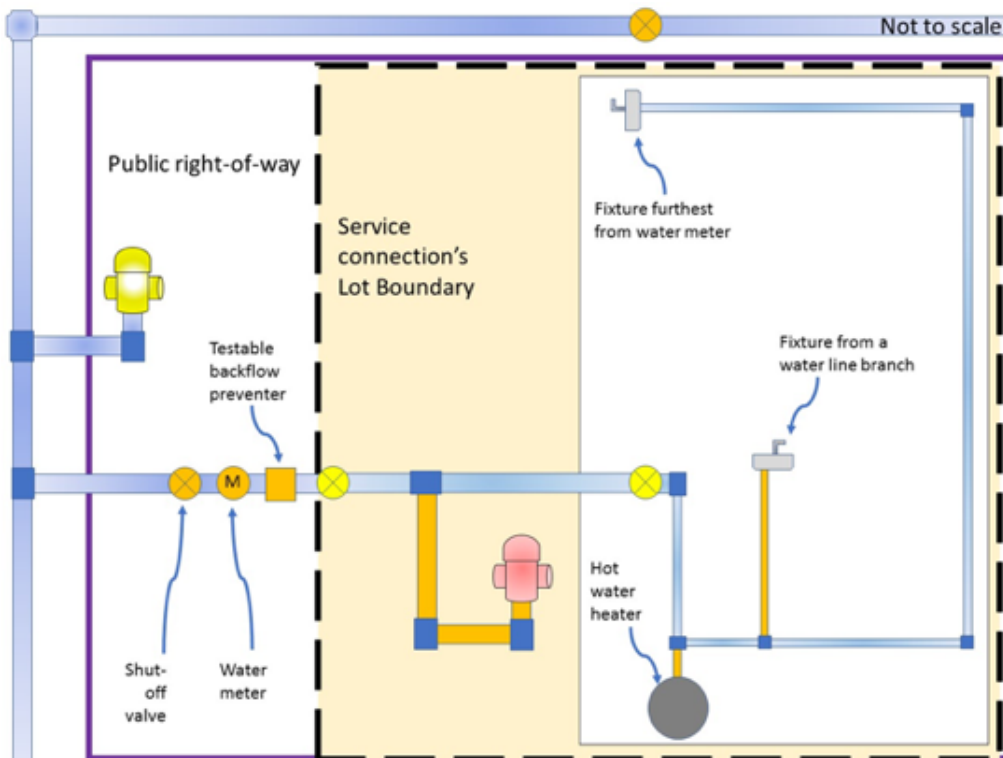

Figure 3. Hypothetical layout of a building's premise plumbing. Orange-colored lines represent aged water following a suspension of use. The farthest fixture has been flushed, branch lines remain to be flushed. Note that no old water exists between the main to the farthest fixture. Note the blue fresh water has replaced the orange stale water in this line.

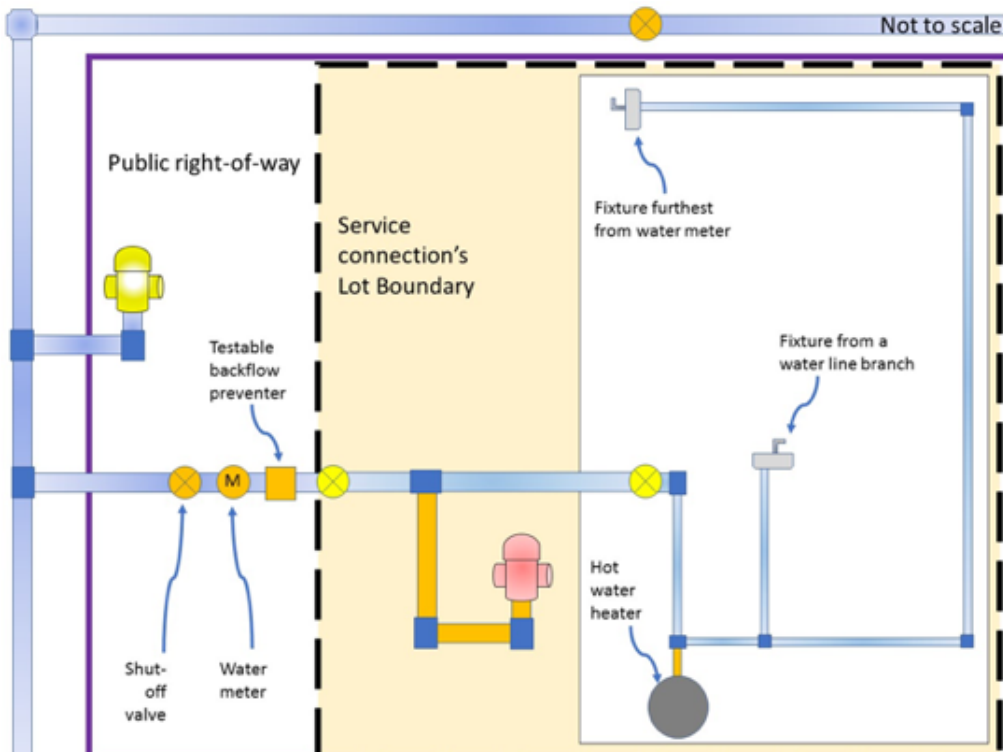

Figure 4. Hypothetical layout of a building's premise plumbing. Orange-colored lines represent aged water following a suspension of use. All cold water fixtures have been flushed. Note the blue fresh water has replaced the orange stale water in the branch.

Hot water lines may be flushed at the same time as cold water lines to speed up the process. This would remove the old water from the water heater and its branch lines.